



Technical Data

Specification & Capacities

SPX532

OVERALL DIMENSIONS

SPX532CDH JIB STOWED

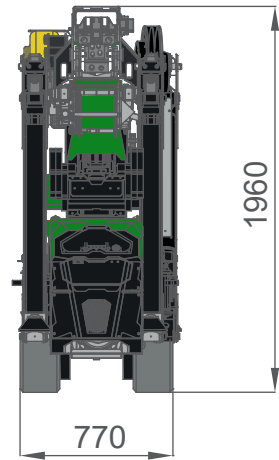
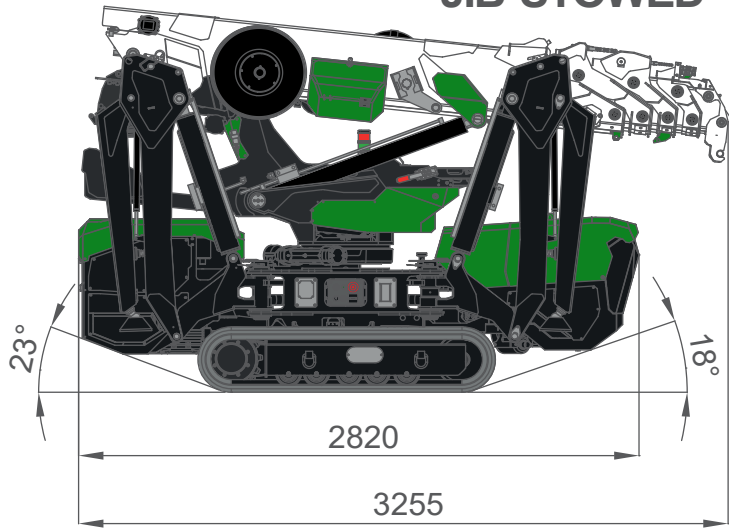

JIB MOUNTED

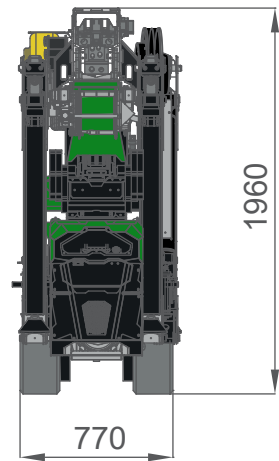
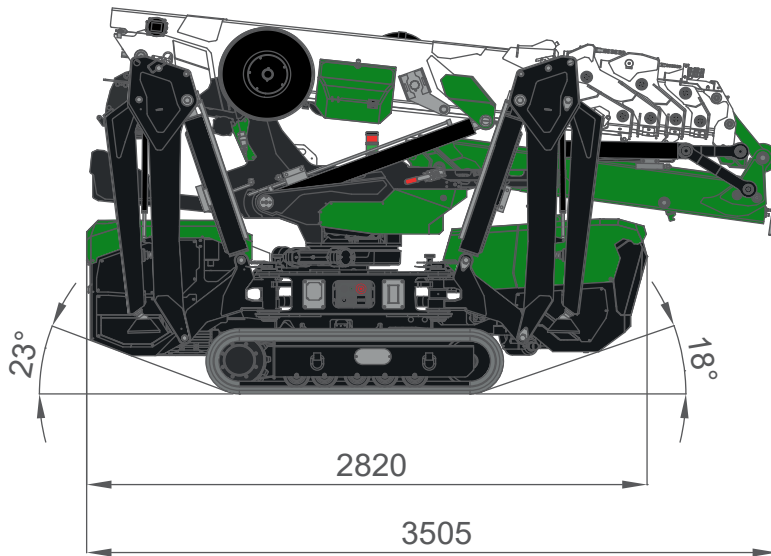

EXTENDED TRACKS

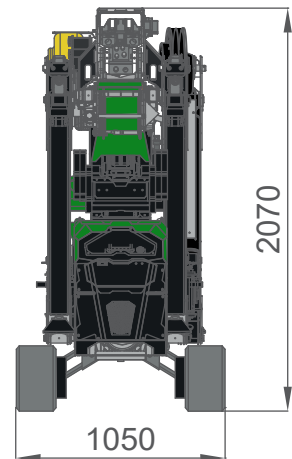
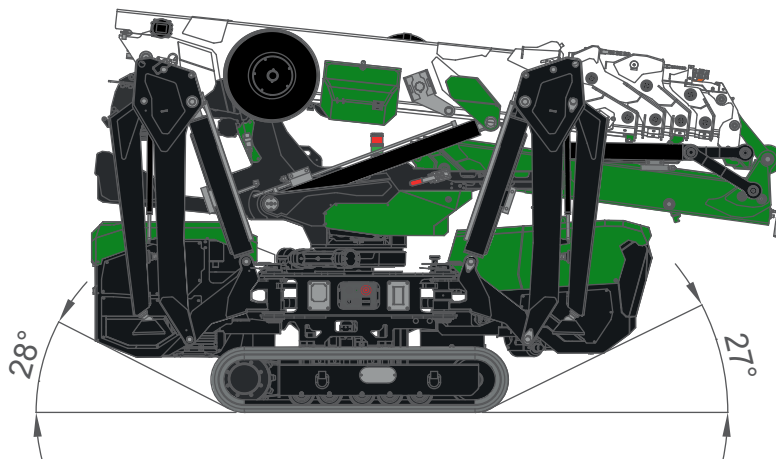

OVERALL DIMENSIONS



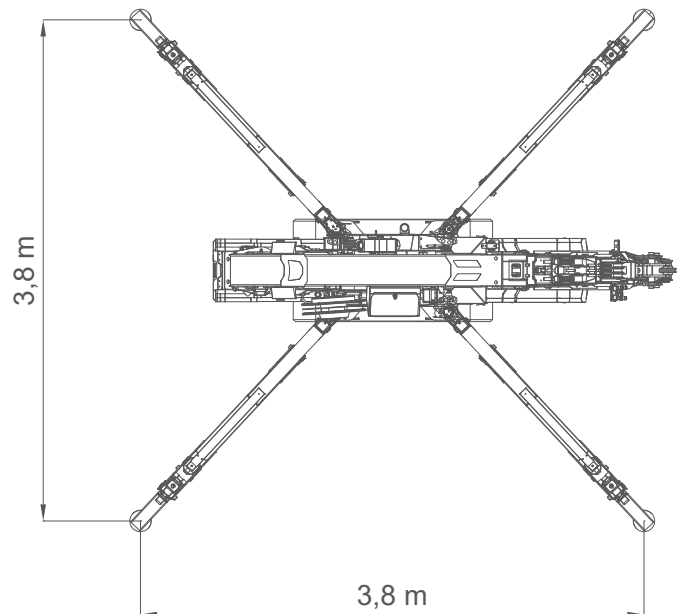
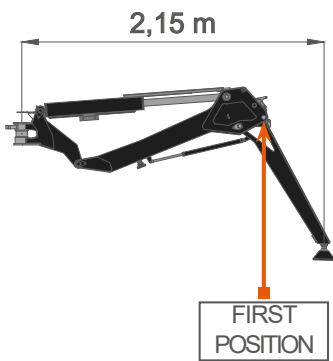

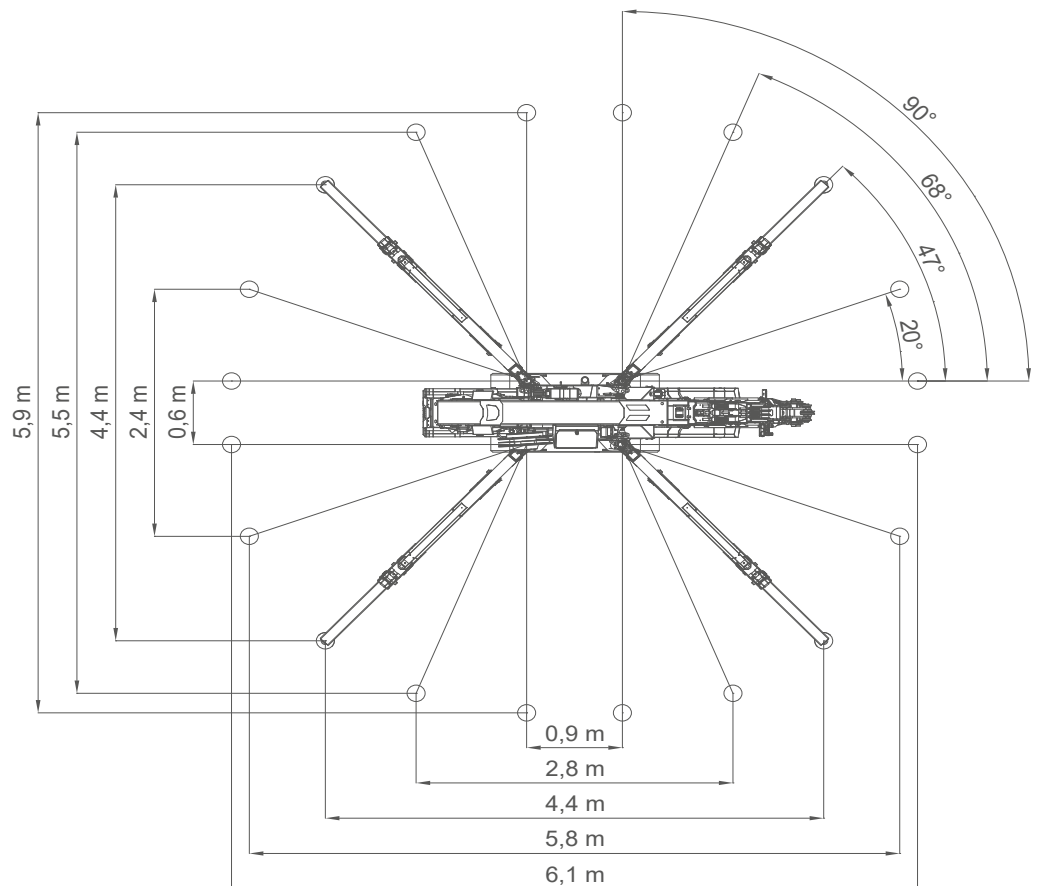
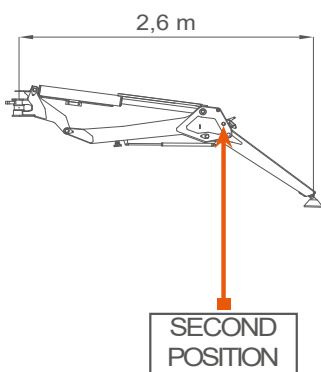

SQUARE OUTFRIGGER 1ST POSITION STABILITY















OUTRIGGER 2ND POSITION FULL STABILITY



OVERALL INFORMATION

		Name/ version	kg*
WEIGHTS	 Crane	CDH, CL, CL2	2520
	 Winch	W800.6	52
	 Hookblock	SINGLE FALL	20
		MULTIPLE FALL	49
	 Power Pack	1-PHASE POWERPACK	52
		3-PHASE POWERPACK	63
	 Jib	JIB1200GX	50
		JIB1000.2H1MX	210
		MANUAL EXTENSION	14
		PULLEY HEAD	8
 Grabber	JIB500GR	217	
 Outriggers mats	OM400	17	

ENGINE	 Engine	KUBOTA D902-E4B	
	kW Power	16,1kW 22HP	
	 Fuel	DIESEL	
ELECTRIC	 Tank	L	10
	 Lithium Battery	CL: 24V 300Ah	
	kW Power	24V-3F 5,5kW 7,5HP	
	 Lithium Battery	CL2: 48V 200Ah	
	kW Power	48V-3F 7,0kW 9,5HP	
	HYDRAULIC	 Hydraulic Oil	ISO 6743-4:HFDU with VG46 viscosity class
Working temp			<70°C
L			40
MOVEMENTS	 Travel Speed	km/h	CDH: 2,7 CL, CL2 : 1,8
	 Gradeability	20° (36%) [†]	
	 Track Load	kg/cm ²	0,63
	 Outrigger Load	kg	3000 [‡]
	 Working Angle	0°/80°	
		s	30
	 Slewing	360°	
		rpm	0,85
	 Boom Telescoping	m	2,5 - 10,8
		s	40

*: Dry weight
 †: Engine working limit
 ‡: Static lifting

HOIST PERFORMANCE

GEARWINCH	Layer	Max line pull	Standard rope speed	Highest rope speed
		kg	m/min	m/min
	1	785		25
	2	730		27
	3	680		29
	4	640		31
	5	600		33
ROPE	Wire rope	Ø	Total length	Max load
		mm	m	kg
	19x7 right lang lay Non rotating	7	81	4700
PISTON WINCH	Layer	Max line pull	Standard rope speed	Highest rope speed
		kg	m/min	m/min
	1	980*		16
	2	910*		17
	3	860*		19
	4	810*		20
ROPE	Wire rope	Ø	Total length	Max load
		mm	m	kg
	19x7 right lang lay Non rotating	7	68	4700
HOOK BLOCK	Load	N° of		Block type
	kg	Sheaves	Lines	
	3200	2	4	Multiple fall block
	2400	1	3	
	1600	1	2	
	800	-	1	Single fall block

*: LMI limited at 800kg

PULLEY HEAD AND HOOKBLOCK

TILTING PULLEY HEAD

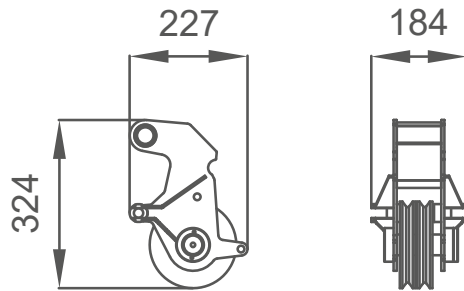

SINGLE FALL

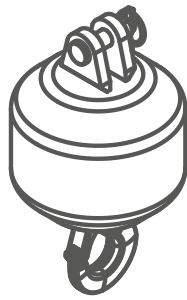

MULTIPLE FALLS

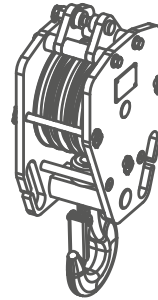

CRANE PERFORMANCE

CRANE PERFORMANCE	d	1,1 m	1,8 m	2,2m
	J7			
J6				
J5				
J4				
J3				
J2				
J1	PICK & CARRY			
J0	NO LIFTING CAPACITY			
		2,2 x 2,2 m	3,6 x 3,6 m	4,4 x 4,4 m
STABILITY AREA				

STABILITY EXAMPLES

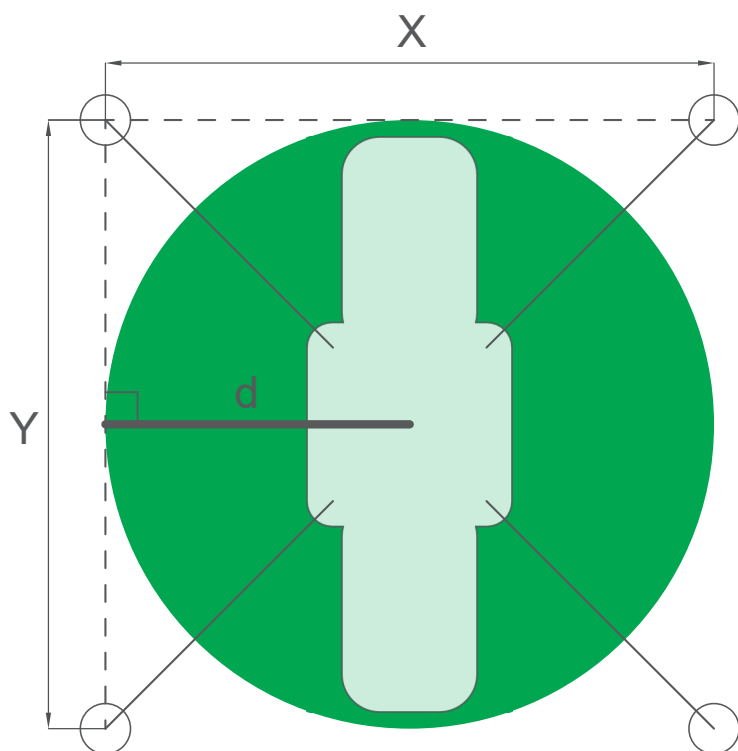

Example 1:
Square stability area.

$X = 4,4 \text{ m}$
 $Y = 4,4 \text{ m}$
 $d = 2,2 \text{ m}$

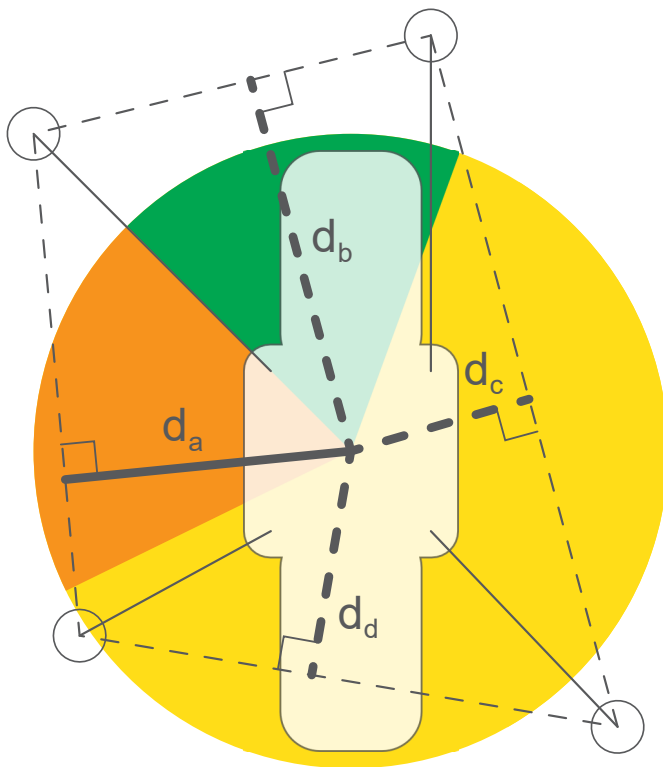

Example 2:
Asymmetric stability area.

$d_a = 1,9 \text{ m}$
 $d_b = 2,2 \text{ m}$
 $d_c = 1,3 \text{ m}$
 $d_d = 1,3 \text{ m}$

Example 3:
Close outriggers stability area.

$X = 0,6 \text{ m}$
 $Y = 5,0 \text{ m}$
 $d_a = 0,3 \text{ m}$
 $d_b = 2,5 \text{ m}$
 $d_c = 0,3 \text{ m}$
 $d_d = 2,5 \text{ m}$

d_b and d_d should be J7 geometrically but is limited to J0 anyway because too narrow.

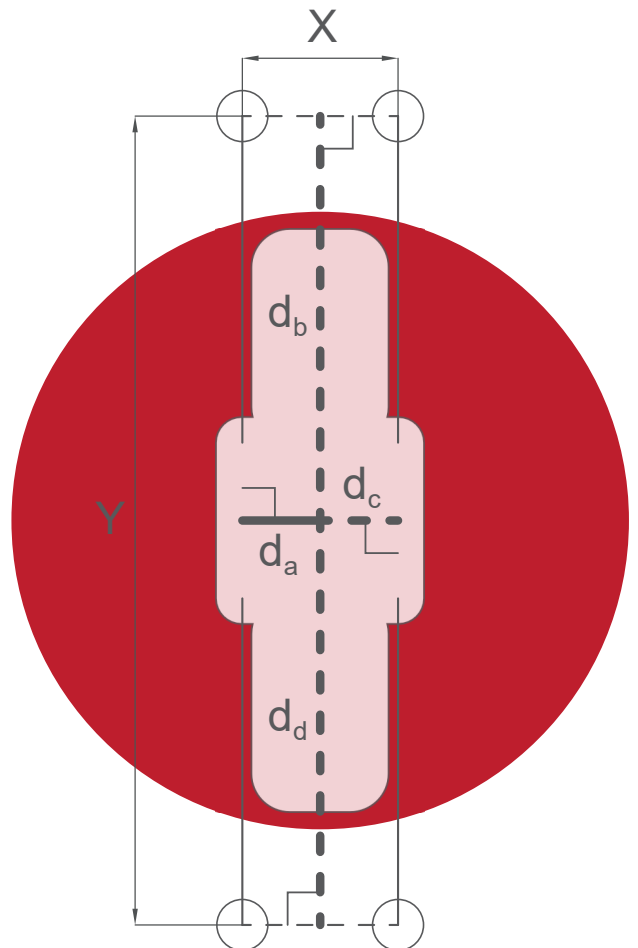

SPX532 - MAIN BOOM

 CRANE PERFORMANCE: J7										
[m] L →	2,6	2,7	3,7	4,7	5,7	6,7	7,7	8,7	9,7	10,3
1	3,20	3,00	2,65	2,40	2,30	2,10	1,73	1,65	1,55	1,45
2	3,20	3,20	2,60	2,30	2,09	1,88	1,73	1,55	1,45	1,27
3			2,60	2,30	1,95	1,70	1,53	1,41	1,26	1,17
4				2,25	1,75	1,55	1,35	1,30	1,18	1,03
5					1,50	1,30	1,15	1,12	1,00	0,96
6						1,10	1,10	1,04	0,93	0,90
7							0,80	0,80	0,80	0,80
8								0,65	0,64	0,64
9									0,53	0,52
9,45*										0,47
↑ R [m]	[ton]									

LC532_V202_0521_BP_GANCIO_J7

 CRANE PERFORMANCE: J6										
[m] L →	2,6	2,7	3,7	4,7	5,7	6,7	7,7	8,7	9,7	10,3
1	3,20	3,00	2,65	2,40	2,30	2,10	1,73	1,65	1,55	1,45
2	3,20	3,20	2,60	2,30	2,09	1,88	1,73	1,55	1,45	1,27
3			2,60	2,30	1,95	1,70	1,53	1,41	1,26	1,17
4				1,70	1,65	1,50	1,35	1,30	1,18	1,03
5					1,10	1,10	1,10	1,00	1,00	0,96
6						0,80	0,80	0,80	0,80	0,80
7							0,60	0,60	0,60	0,60
8								0,48	0,48	0,48
9									0,40	0,40
9,45*										0,32
↑ R [m]	[ton]									

LC532_V202_0521_BP_GANCIO_J6

SPX532 - MAIN BOOM

CRANE PERFORMANCE: J5					
[m] L →	2,6	2,7	3,7	4,7	5,7
1	1,50	1,50	1,00	0,70	0,40
2	1,20	1,20	0,70	0,50	0,40
3			0,60	0,45	0,30
4				0,35	0,28
5					0,20
↑ R [m]	[ton]				

LC532_V202_0521_BP_GANCIO_J5

CRANE PERFORMANCE: J1		
[m] L →	2,6	2,7
1	0,40	0,40
2		0,11
↑ R [m]	[ton]	

LC532_V202_0521_BP_GANCIO_J1

*: Refers to hook configuration. Pulley configuration is 0,1m longer.

SPX532 - JIB1000.2H1MX

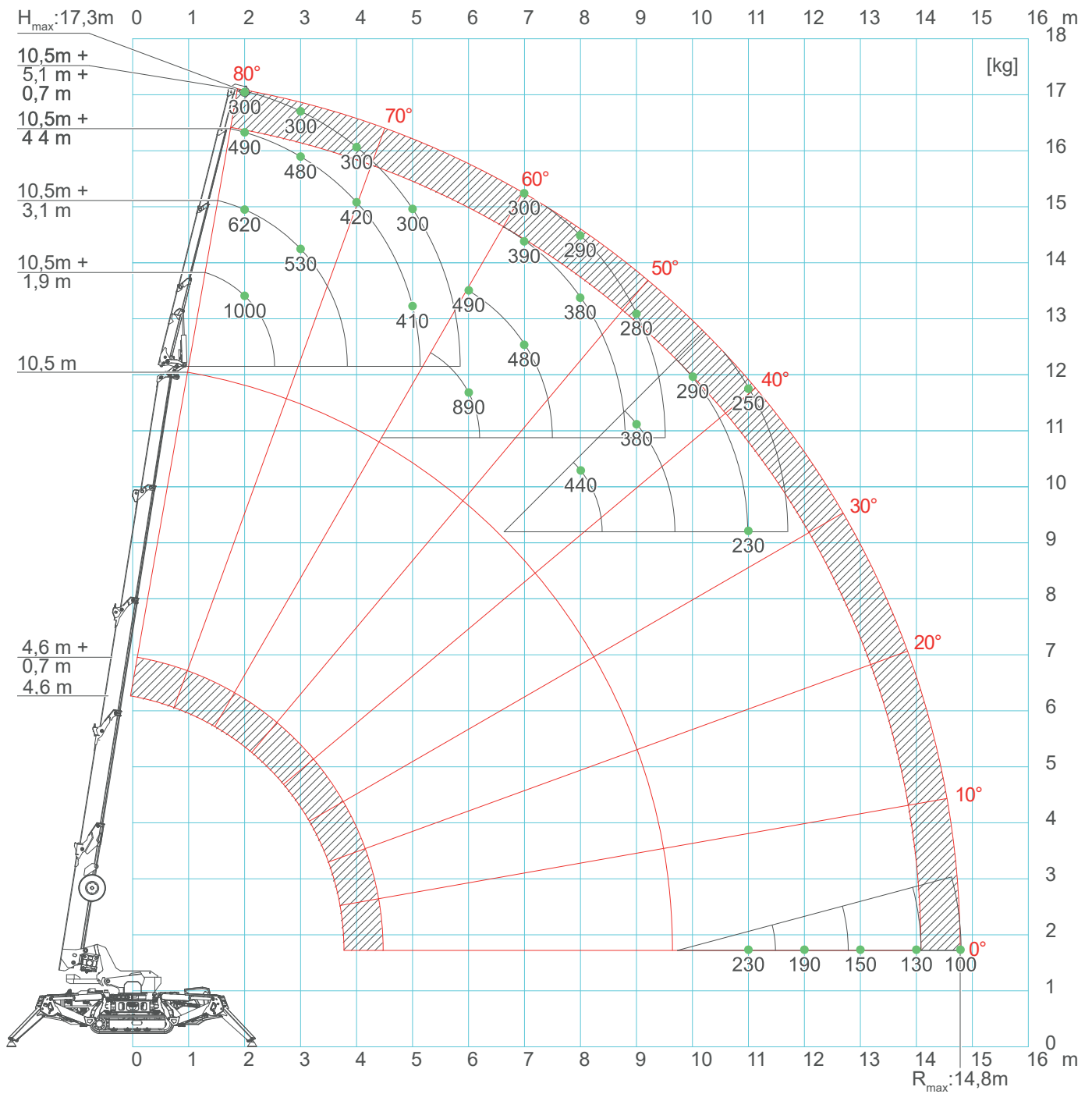

*: Refers to hook configuration. Pulley configuration is 0,1m longer.

SPX532 - JIB1000.2H1MX

CRANE PERFORMANCE: J7				
[m] L _J →	1,9	3,1	4,4	5,1
1	1,00	0,70	0,50	0,46
2	1,00	0,62	0,49	0,40
3	1,00	0,53	0,48	0,35
4	1,00	0,51	0,42	0,33
5	1,00	0,50	0,41	0,32
6	0,89	0,49	0,40	0,31
7	0,67	0,48	0,39	0,30
8	0,44	0,40	0,38	0,29
9	0,38	0,38	0,34	0,28
10	0,29	0,29	0,29	0,25
11		0,23	0,23	0,23
12		0,19	0,19	0,19
13			0,15	0,15
14			0,14	0,13
14,8				0,10
↑ R [m]	[ton]			

LC532_V202_0521_JIB1000_GANCIO_J7

CRANE PERFORMANCE: J6				
[m] L _J →	1,9	3,1	4,4	5,1
1	1,00	0,70	0,50	0,46
2	1,00	0,54	0,45	0,40
3	1,00	0,50	0,43	0,35
4	1,00	0,48	0,36	0,30
5	0,80	0,43	0,33	0,29
6	0,59	0,40	0,30	0,28
7	0,42	0,38	0,29	0,27
8	0,30	0,30	0,28	0,26
9	0,20	0,20	0,20	0,20
10	0,14	0,14	0,14	0,14
11	0,11	0,11	0,11	0,11
↑ R [m]	[ton]			

LC532_V202_0521_JIB1000_GANCIO_J6

SPX532 - JIB1000.2H1MX

		CRANE PERFORMANCE: J5			
[m] L _J →	1,9	3,1	4,4	5,1	
1	1,00	0,53	0,27	0,22	
2	0,80	0,42	0,25	0,21	
3	0,70	0,40	0,24	0,20	
4	0,40	0,30	0,23	0,19	
5	0,28	0,24	0,22	0,18	
↑ R [m]	[ton]	LC532_V202_0521_JIB1000_GANCIO_J5			

		CRANE PERFORMANCE: J1	
[m] L _J →	1,9		
1	0,12		
2	0,10		
3	0,10		
4	0,05		
↑ R [m]	[ton]	LC532_V202_0521_JIB1000_GANCIO_J1	

SPX532 - JIB1200GX

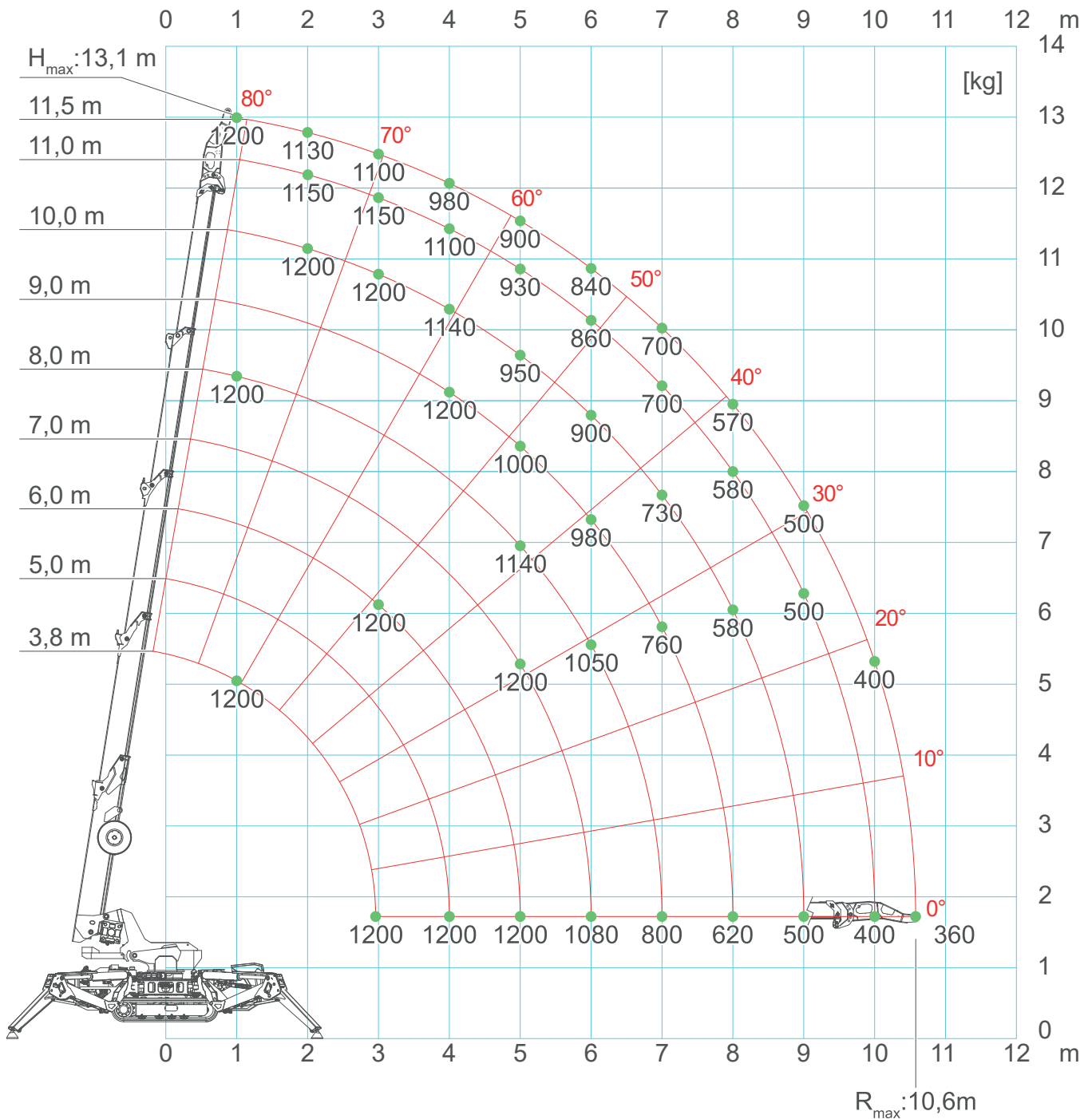

*: With manual extension on maximum weight is limited to 300kg.

SPX532 - JIB1200GX

 CRANE PERFORMANCE: J7										
[m] L →	2,6	2,7	3,7	4,7	5,7	6,7	7,7	8,7	9,7	10,3
L+L _J →	3,7	3,8	4,8	5,8	6,8	7,8	8,8	9,8	10,8	11,4
1	1,25	1,25	1,25	1,25	1,25	1,25	1,25	1,25	1,25	1,25
2	1,25	1,25	1,25	1,25	1,25	1,25	1,25	1,25	1,15	1,13
3	1,25	1,25	1,25	1,25	1,25	1,25	1,25	1,25	1,15	1,10
4			1,25	1,25	1,25	1,25	1,25	1,14	1,10	0,98
5				1,25	1,25	1,14	1,00	0,95	0,93	0,90
6					1,04	1,00	0,98	0,90	0,86	0,84
7						0,78	0,76	0,73	0,70	0,70
8							0,61	0,58	0,58	0,57
9								0,49	0,49	0,49
10									0,40	0,40
10,5										0,35
↑ R [m]	[ton]									

LC532_V202_0521_JIB1200GX_GANCIO_J7

 CRANE PERFORMANCE: J6										
[m] L →	2,6	2,7	3,7	4,7	5,7	6,7	7,7	8,7	9,7	10,3
L+L _J →	3,7	3,8	4,8	5,8	6,8	7,8	8,8	9,8	10,8	11,40
1	1,25	1,25	1,25	1,25	1,25	1,25	1,25	1,25	1,25	1,25
2	1,25	1,25	1,25	1,25	1,25	1,25	1,25	1,25	1,15	1,13
3	1,25	1,25	1,25	1,25	1,25	1,25	1,25	1,25	1,15	1,00
4			1,25	1,25	1,25	1,25	1,25	1,14	1,10	0,98
5				1,08	1,00	0,96	0,95	0,93	0,92	0,90
6					0,78	0,75	0,71	0,68	0,62	0,60
7						0,58	0,56	0,54	0,50	0,48
8							0,44	0,43	0,42	0,40
9								0,35	0,35	0,32
10									0,29	0,28
10,5										0,25
↑ R [m]	[ton]									

LC532_V202_0521_JIB1200GX_GANCIO_J6

*: With manual extension on maximum weight is limited to 300kg.

SPX532 - JIB1200GX

CRANE PERFORMANCE: J5				
[m] L →	2,6	2,7	3,7	4,7
L+L _J →	3,7	3,8	4,8	5,8
1	1,20	1,00	0,70	0,40
2	1,11	0,60	0,50	0,36
3	0,54	0,54	0,40	0,26
4			0,28	0,22
5				0,15
↑ R [m]	[ton]			

LC532_V202_0521_JIB1200GX_GANCIO_J5

SPX532 - JIB500GR

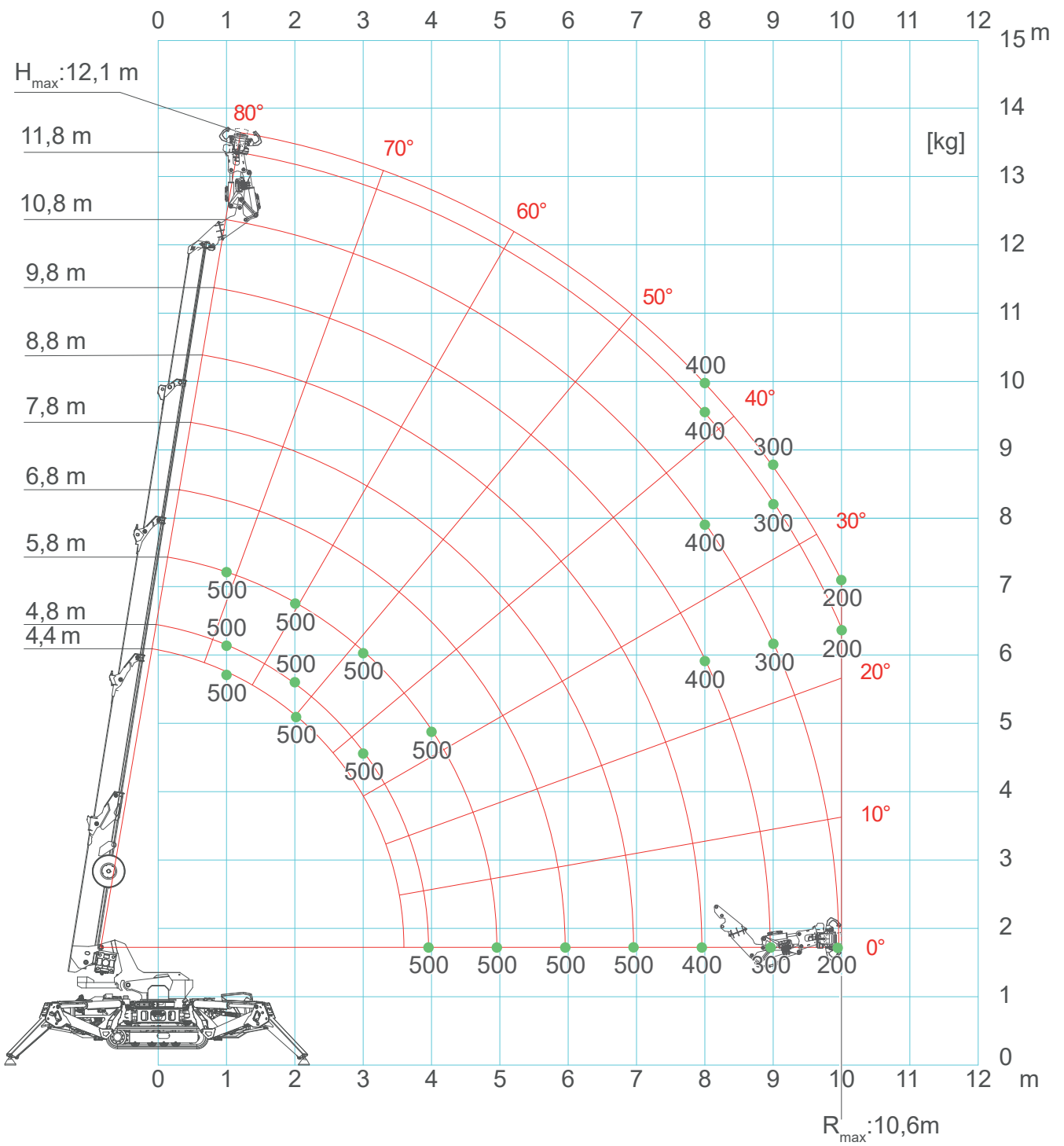

SPX532 - JIB500GR

		CRANE PERFORMANCE: J7									
[m] L →	2,6	3,0	4,0	5,0	6,0	7,0	8,0	9,0	10,0	10,3	
L+L _J →	4,4	4,7	5,7	6,7	7,7	8,7	9,7	10,7	11,7	12,0	
1	0,55	0,55	0,55	0,55	0,55	0,55	0,55	0,55	0,55	0,55	
4	0,55	0,55	0,55	0,55	0,55	0,55	0,55	0,55	0,55	0,55	
5			0,55	0,55	0,55	0,55	0,55	0,55	0,55	0,55	
6				0,55	0,55	0,55	0,55	0,55	0,55	0,55	
7					0,55	0,55	0,55	0,55	0,55	0,55	
8						0,40	0,40	0,39	0,39	0,39	
9							0,29	0,28	0,28	0,28	
10								0,20	0,20	0,20	
↑ R [m]	[ton]										

LC532_V202_0521_JIB1200GX_GANCIO_J7

		CRANE PERFORMANCE: J6									
[m] L →	2,6	3,0	4,0	5,0	6,0	7,0	8,0	9,0	10,0	10,3	
L+L _J →	4,4	4,7	5,7	6,7	7,7	8,7	9,7	10,7	11,7	12,0	
1	0,55	0,55	0,55	0,55	0,55	0,55	0,55	0,55	0,55	0,55	
4	0,55	0,55	0,55	0,55	0,55	0,55	0,55	0,55	0,55	0,55	
5			0,55	0,55	0,55	0,55	0,55	0,55	0,55	0,55	
6				0,52	0,51	0,49	0,46	0,44	0,43	0,43	
7					0,35	0,34	0,33	0,31	0,31	0,31	
8						0,23	0,22	0,21	0,21	0,21	
8,1											
↑ R [m]	[ton]										

LC532_V202_0521_JIB1200GX_GANCIO_J6

SPX532 - JIB1200GX

		CRANE PERFORMANCE: J5		
		[m] L →	2,6	3,0
L+L _J →	3,7	4,1	5,1	
1	0,55	0,55	0,55	
2	0,55	0,55	0,55	
3	0,55	0,40	0,40	
4		0,30	0,30	
5			0,20	
↑ R [m]	[ton]			

LC532_V202_0521_JIB1200GX_GANCIO_J5

ACCESSORIES SPX532CDH

ATTACHMENTS & TOOLS

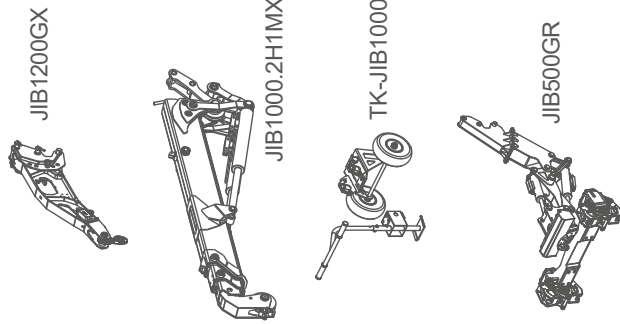

ELECTRIC POWER PACK

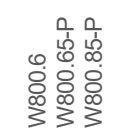
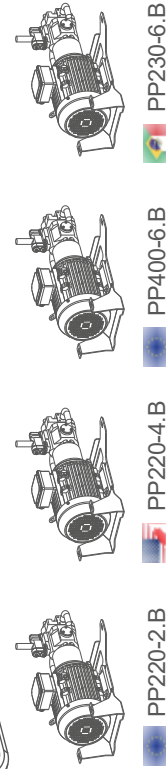

LAYOUT

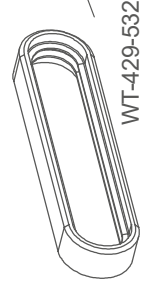
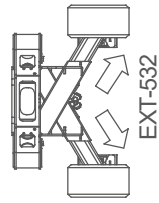
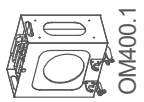

J-CONNECT

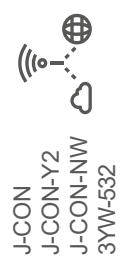

ACCESSORIES SPX532CL

ATTACHMENTS & TOOLS

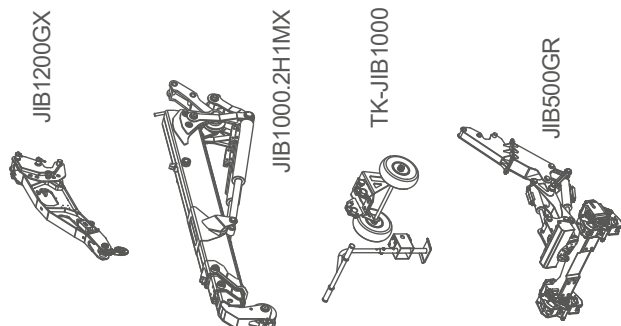

W800.6
W800.65-P
W800.85-P



Pulley Block 4T



OUT-LED-1



VAI



HA-SPX532

CRANE OPTIONS



LAYOUT

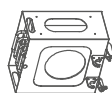

OM400.1

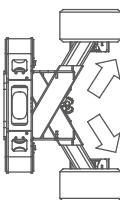

EXT-532

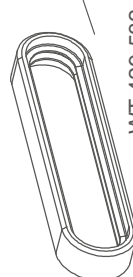

WT-429-532



WUK-CL



ARTIC-OIL-532

BATTERY CHARGERS



BC3-110V60A



BC-EXT-532-650



J-CONNECT

J-CON
J-CON-Y2
J-CON-NW
3YW-532

ACCESSORIES FEATURES JIB1000.2H1MX

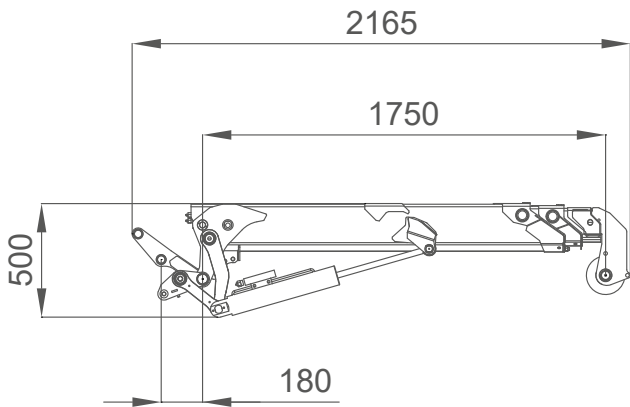
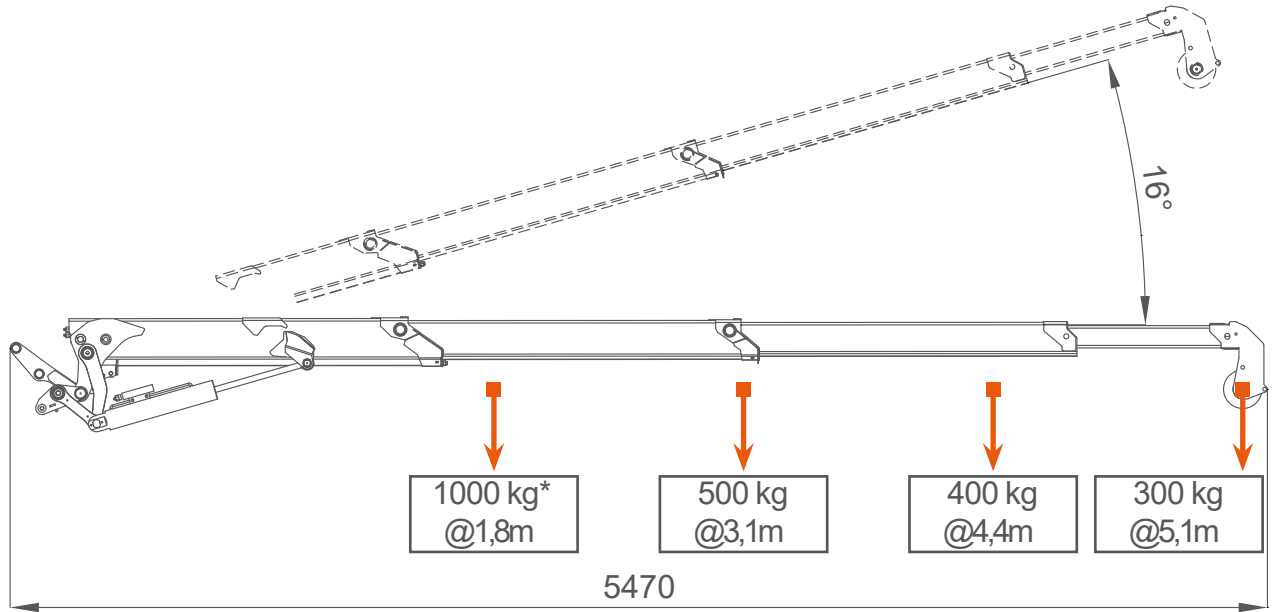

*: Maximum capacity using hook, with winch this is limited to single fall winch capacity (800kg).



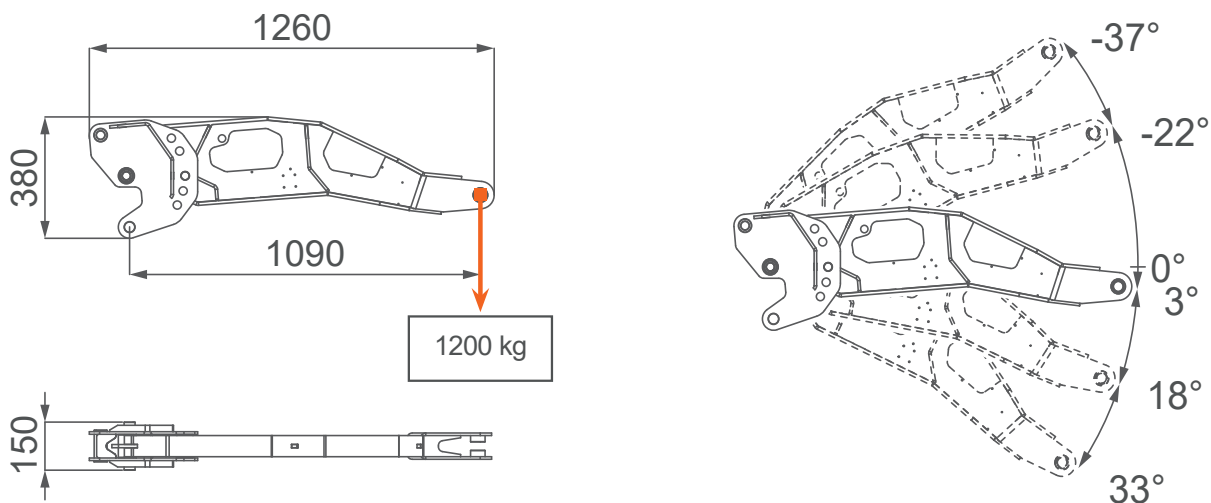



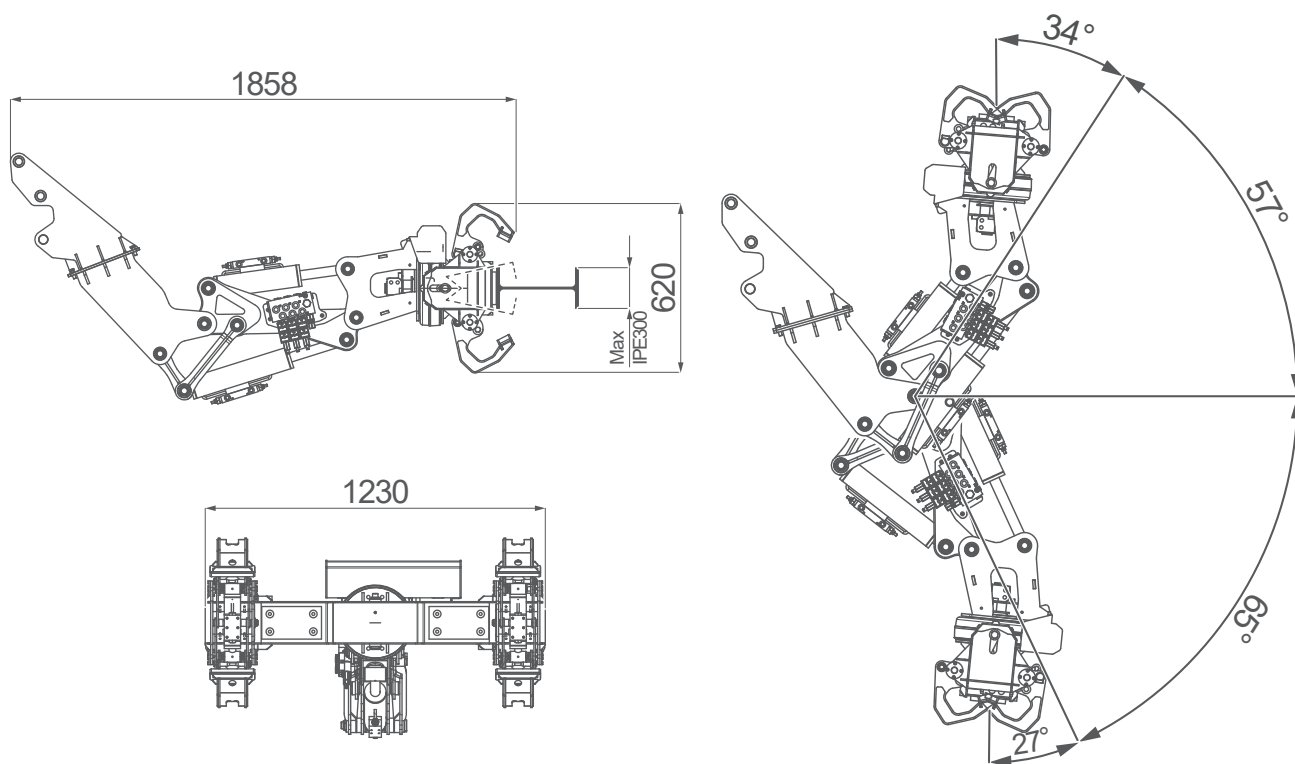













































JIB1200GX



JIB500GR



SYMBOLS

	Weight		Engine		Boom Angle		Minipicker
	Counterweight		Diesel Fuel		Boom Length		Back Wheel Loading Point
	Crane		Petrol Fuel		Boom Radius		Front Wheel Loading Point
	Dimensions		Tank		Jib on Board		Working Radius
	Stabilization Area		Power		Without Jib on Board		Stabilizing Bar
	Travel Speed		Battery		Jib Hook Radius		Standard
	Gradeability		Lithium Battery		Jib Length and Angle		Factory max. load
	Outrigger Load		Powerpack		Jib Length		Building site max. load
	Track Loading		Main Winch		Jib Radius		Maximum inclination of the machinery
	Outriggers Setup		Hookblock		Manipulator Length		Hydraulic oil
	Ext Tracks Width		Slewing		Manipulator Radius		Winter Warm-up Kit
	Chart on Tracks		Slewing Locked		Number of vacuum pads		Horizontal Boom Angle
	Slope		Outriggers mats		Grabber		White Pads for Steel Tracks

REMARKS REFERRING TO LOADCHART

- The load charts are calculated according to EN 13000.
- For the calculation of the load charts at least a wind speed of 9m/s (33km/h) and regarding the load a sail area of 1m² per ton load and a wind resistance coefficient of 1.2 on the load have been taken into account. For lifting of loads with large sail areas and/or high wind resistance coefficients the maximum wind speed as stated in the load charts has to be reduced.
- Lifting capacities are given in kilograms.
- The weight of the hook blocks and hooks is part of the load and therefore it must be deducted from the lifting capacities.
- Working radii are measured from the slewing centre.
- The lifting capacities given for the telescopic boom apply if the folding jib is removed.
- Subject to modification of lifting capacities.